

# AMPLIFIERS FOR SENSORS

**OP** = optocoupled static output  
**TOP** = timed optocoupled static output  
**RL** = relay output  
**TRL** = timed relay output

**24** = supply voltage 24 Vdc or Vac  
**1122** = supply voltage 85 ± 260 Vac

<b>AM</b>	<b>OP</b>	<b>24</b>	<b>/</b>	<b>2</b>
-----------	-----------	-----------	----------	----------

n° channels



OPTOCOUPLED STATIC OUTPUTS •

1 or 2 channels •

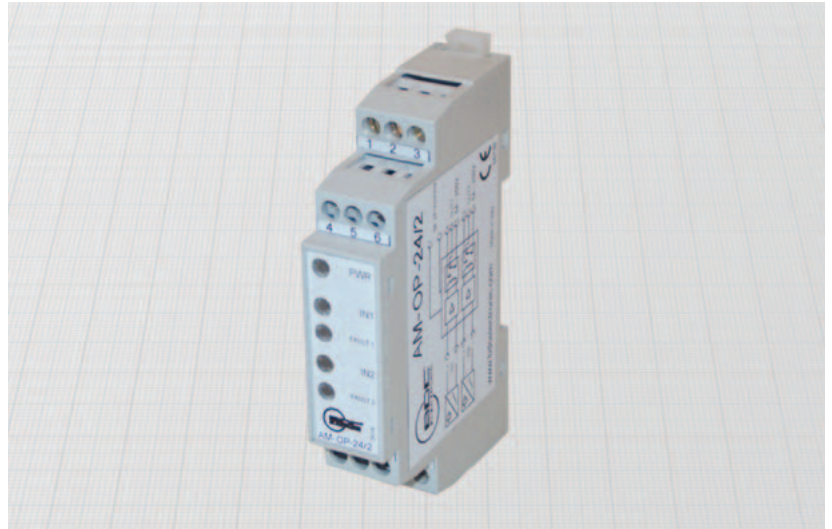
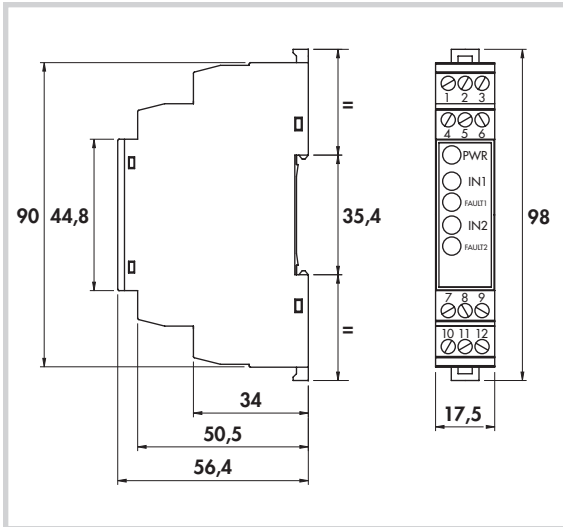

Connections AM-OP-24/2

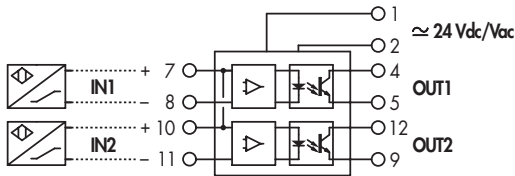

Connections AM-OP-1122/1

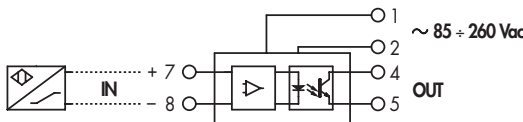

Dip-Switches settings

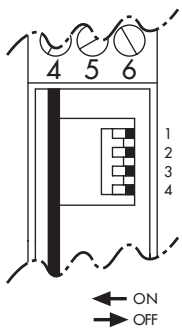

DIP	POSITION	CONFIGURATION
1	OFF	OUT1 N.O.
	ON	OUT1 N.C.
2	OFF	IN1 Failure detection disabled
	ON	IN1 Failure detection enabled
3	OFF	OUT2 N.O.
	ON	OUT2 N.C.
4	OFF	IN2 Failure detection disabled
	ON	IN2 Failure detection enabled

General Features:

These units allow to amplify signals from NAMUR sensors or contacts. Each output is electrically insulated from each other, from power supply and from all the inputs. It is possible to configure them as N.O. or N.C. and use them as PNP or NPN. They are protected against over voltages on lines, overload and short circuit. When used for NAMUR sensors, the indication of failures is visible with a red LED on the front panel for interruptions or short circuits on the input lines. The configuration dip-switches are easily accessible removing the front panel. Suitable for DIN rail mounting.

Technical data:

- Supply voltage: see ordering references
- Frequency of power supply: DC or 50 - 60 Hz
- Power consumption max: see ordering references
- Working temperature: -25 ÷ +60°C
- Storage temperature: -40 ÷ +80°C
- According to EN60947-5-6
- Electromagnetic compatibility (EMC) according to EN61000-6-2/-4 **CE**
- Degree of protection: IP20

INPUT PARAMETERS

- Switching point to ON: 1,55 ÷ 1,75 mA
- Switching point hysteresis: 0,2 mA
- Failure detection thresholds: open circuit detection when I < 0,05 mA  
short circuit detection when I > 7,45 mA (Ri < 100Ω)

OUTPUTS

- Output:t function: N.O. or N.C. as for DIP-SW settings
- Polarity: NPN/PNP
- Switching frequency max: 900 Hz
- Input/output delay max: 700 μs
- Output current max: 300 mA
- Max applicable voltage through the load: 65 V
- Voltage drop max in ON condition: 1,7 V
- Insulation from power supply and from inputs: 2500 V

SUPPLY VOLTAGE	N. CHANNELS	POWER CONSUMPTION MAX mA	ORDERING REFERENCES
24 V a.c. - d.c. ± 20%	2	60	<b>AM-OP-24/2</b>
85 ÷ 260 Va.c.	1	20	<b>AM-OP-1122/1</b>

# AMPLIFIERS FOR SENSORS

## • OPTOCOUPLED STATIC OUTPUT

### • 1 Timed channel

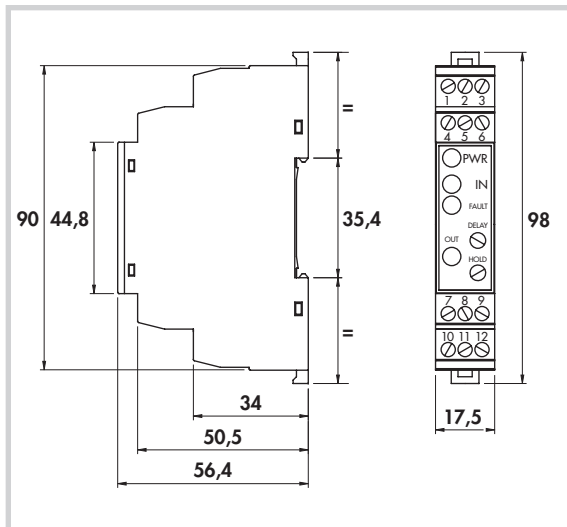

#### Connections AM-TOP-24/1

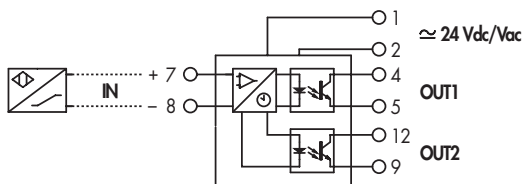

#### Connections AM-TOP-1122/1

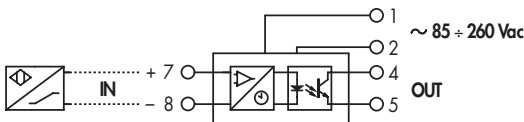

#### Dip-Switches settings

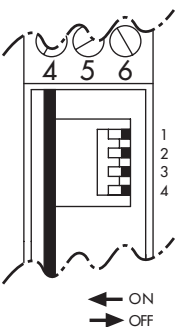

DIP	POSITION	CONFIGURATION
1	OFF	OUT1 N.O.
	ON	OUT1 N.C.
2	OFF	IN Failure detection disabled
	ON	IN Failure detection enabled
3	Not used	
4	OFF	OUT2 = OUT1
	ON	OUT2 = Remote failure indication

#### General Features:

These units allow to amplify signals from NAMUR sensors or contacts. The delay time and hold time respect the input signal are adjustable through potentiometers on the front panel. Each output is electrically insulated from each other, from power supply and from all the inputs. It is possible to configure them as N.O. or N.C. and use them as PNP or NPN. They are protected against over voltages on lines, overload and short circuit. On the 24V version is also possible to configure the OUT2 with the same function of OUT1 or use it as remote failure indication. When used for NAMUR sensors, the indication of failures is visible with a red LED on the front panel for interruptions or short circuits on the input lines.

The configuration dip-switches are easily accessible removing the front panel. Suitable for DIN rail mounting.

#### Technical data:

- Supply voltage: see ordering references DC or 50 - 60 Hz
- Frequency of power supply: see ordering reference
- Power consumption max: - 25 ÷ + 60° C
- Working temperature: - 40 ÷ + 80° C
- Storage temperature: IP20
- Degree of protection:
- According to EN60947-5-6
- Electromagnetic compatibility (EMC) according to EN61000-6-2/-4

#### INPUT PARAMETERS

- Switching point to ON:  $\geq 1,75$  mA
- Switching point hysteresis: 0,2 mA
- Failure detection thresholds: open circuit detection when  $I < 0,05$  mA
- short circuit detection when  $I > 7,45$  mA ( $R_i < 100$  ohm)

#### OUTPUTS

- Output function: N.O. or N.C. as for DIP-SW settings
- Polarity: NPN/PNP
- Switching frequency max: 900Hz
- Input/output delay max: 700µs
- Output current max: 300 mA
- Max applicable voltage through the load: 65 V
- Voltage drop max in ON condition: 1,7 V
- Insulation from power supply and from inputs: 2500 V
- Range of delay and hold timing adjustment: 700 µsec ÷ 25,6 sec

SUPPLY VOLTAGE	N. CHANNELS	POWER CONSUMPTION MAX mA	ORDERING REFERENCES
24 V a.c. - d.c. ± 20%	1	60	<b>AM-TOP-24/1</b>
85 ÷ 260 Va.c.	1	20	<b>AM-TOP-1122/1</b>

RELAY OUTPUT •

1 or 2 channels •

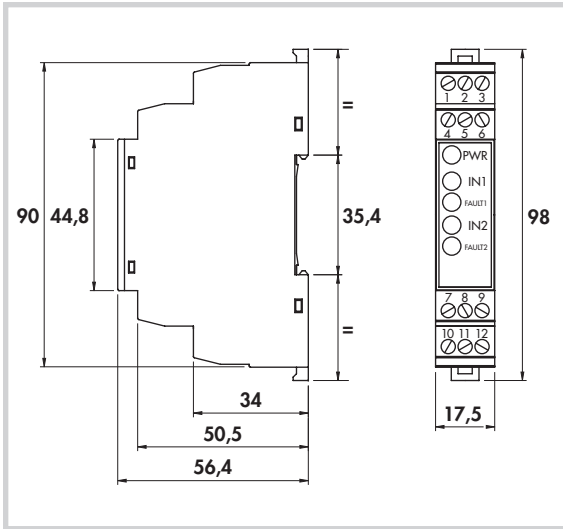

Connections AM-RL-24/2

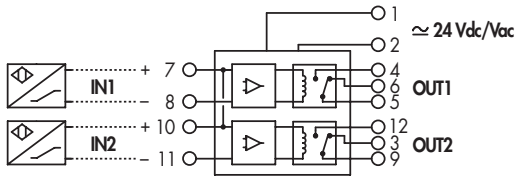

Connections AM-RL-1122/1

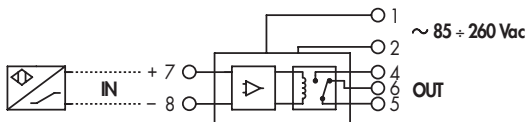

Dip-Switches settings

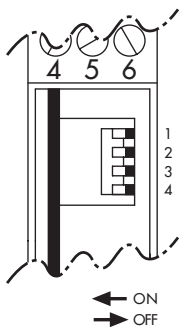

DIP	POSITION	CONFIGURATION
1	OFF	OUT1 N.O.
	ON	OUT1 N.C.
2	OFF	IN1 Failure detection disabled
	ON	IN1 Failure detection enabled
3	OFF	OUT2 N.O.
	ON	OUT2 N.C.
4	OFF	IN2 Failure detection disabled
	ON	IN2 Failure detection enabled

← ON  
→ OFF

General Features:

These units allow to amplify signals from NAMUR sensors or contacts. The relay outputs have changeover N.O. + N.C. contacts electrically insulated from each other, from power supply and from all the inputs. When used for NAMUR sensors, the indication of failures is visible with a red LED on the front panel for interruptions or short circuits on the input lines. The configuration dip-switches are easily accessible removing the front panel. Suitable for DIN rail mounting.

Technical data:

- Supply voltage: see ordering references
- Frequency of power supply: DC or 50 - 60 Hz
- Power consumption max: see ordering references
- Working temperature: -25 ÷ +60°C
- Storage temperature: -40 ÷ +80°C
- Degree of protection: IP20
- According to EN60947-5-6
- Electromagnetic compatibility (EMC) according to EN61000-6-2/-4

INPUT PARAMETERS

- Switching point to ON: ≥ 1,75 mA
- Switching point hysteresis: 0,2 mA
- Failure detection thresholds: open circuit detection when I < 0,05 mA  
short circuit detection when I > 7,45 mA (Ri < 100 ohm)

OUTPUTS

- Output function: NO + NC (SPDT)
- Maximum contact voltage: 250 V
- Rated current: 5 A
- Activation/release typical time: 5/2 msec
- Bouncing on N.O./N.C. contacts typical: 1/5 msec
- Insulation from power supply and from inputs: 2500 V

SUPPLY VOLTAGE	N. CHANNELS	POWER CONSUMPTION MAX mA	ORDERING REFERENCES
24 V a.c. - d.c. ± 20%	2	60	AM-RL-24/2
85 ÷ 260 V a.c.	1	20	AM-RL-1122/1

# AMPLIFIERS FOR SENSORS

## • RELAY OUTPUT

### • 1 Timed channel

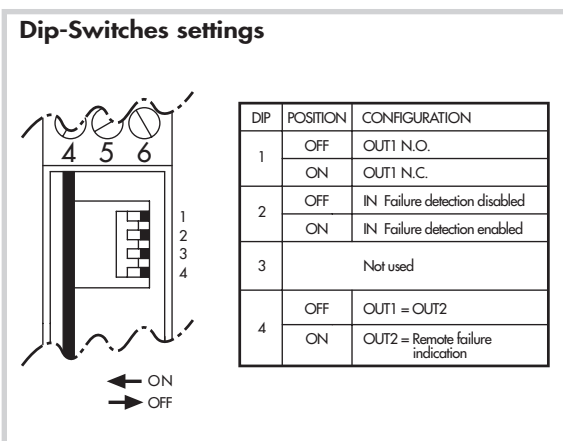
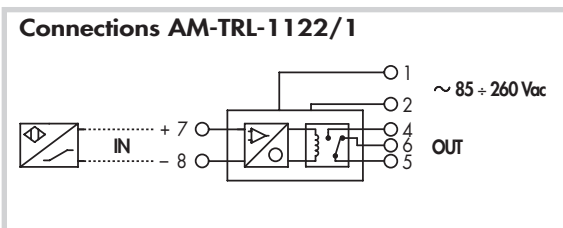
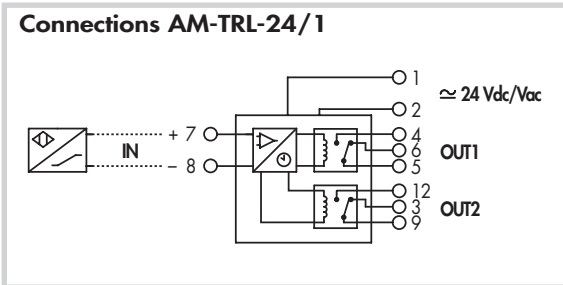
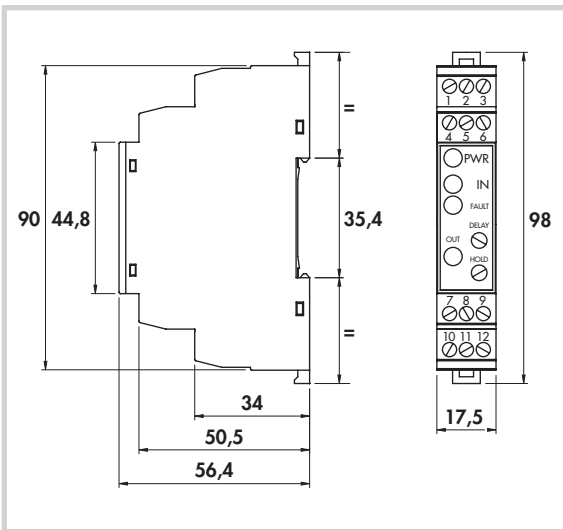

### General Features:

These units allow to amplify signals from NAMUR sensors or contacts. The delay time and hold time respect the input signal are adjustable through potentiometers on the front panel. The relay outputs have changeover N.O.+N.C. contacts electrically insulated from each other, from power supply and from all the inputs. On the 24V version is also possible to configure the OUT2 with the same function of OUT1 or use it as remote failure indication. When used for NAMUR sensors, the indication of failures is visible with a red LED on the front panel for interruptions or short circuits on the input lines.

The configuration dip-switches are easily accessible removing the front panel. Suitable for DIN rail mounting.

### Technical data:

- Supply voltage: see ordering references
- Frequency of supply voltage: DC or 50 - 60 Hz
- Power consumption max: see ordering references
- Working temperature:  $-25^{\circ} \div +60^{\circ} \text{C}$
- Storage temperature:  $-40^{\circ} \div +80^{\circ} \text{C}$
- Degree of protection: IP20
- According to EN60947-5-6
- Electromagnetic compatibility (EMC) according to EN61000-6-2/-4

### INPUT PARAMETERS

- Switching point to ON:  $\geq 1,75 \text{ mA}$
- Switching point hysteresis:  $0,2 \text{ mA}$
- Failure detection thresholds: open circuit detection when  $I < 0,05 \text{ mA}$   
short circuit detection when  $I > 7,45 \text{ mA}$  ( $R_i < 100 \text{ ohm}$ )

### OUTPUTS

- Output function: NO + NC (SPDT)
- Maximum contact voltage:  $250 \text{ V}$
- Rated current:  $5 \text{ A}$
- Bouncing on N.O./N.C. contacts typical:  $1/5 \text{ msec}$
- Insulation from power supply and from inputs:  $2500 \text{ V}$
- Range of delay and hold timing adjustments:  $10 \text{ msec.} \div 25,6 \text{ sec.}$

SUPPLY VOLTAGE	N. CHANNELS	POWER CONSUMPTION MAX mA	ORDERING REFERENCES
24 V a.c. - d.c. $\pm 20\%$	1	60	<b>AM-TRL-24/1</b>
$85 \div 260 \text{ V a.c.}$	1	20	<b>AM-TRL-1122/1</b>